

nea

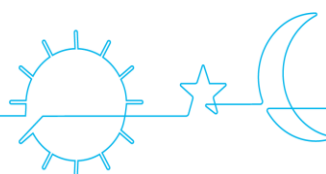

Patient Manual



en

Manufacturer:

SEFAM
144 AV CHARLES DE GAULLE
92200 NEUILLY-SUR-SEINE
FRANCE

Manufacturing and technical service location:

SEFAM
10 ALLEE PELLETIER DOISY
54600 VILLERS-LES-NANCY
FRANCE
TEL: +33 (0) 3 83 44 85 00
www.sefam-medical.com

Technical assistance :

Email: technicalservice@sefam-medical.com

UK Authorised representative:

SEFAM MEDICAL Ltd
UNIT 6. BLACKTHORN WAY
FIVE MILE BUSINESS PARK
LN4 1BF LINCOLN
UNITED KINGDOM
www.sefam-medical.com

CONTENTS

Product description	4
Intended purpose.....	4
Indications.....	4
Contra-indications.....	4
Warnings/Precautions.....	5
Potential undesirable side effects.....	7
Target patient groups.....	7
Intended users.....	7
Environment of use.....	7
Clinical benefits.....	7
Essential performance of the device.....	7
Presentation of the system	8
List of authorized accessories.....	8
Views of the device.....	9
Meaning of symbols.....	9
Installation	11
Standard installation.....	11
Re-installation of the side cover.....	12
Installation with cigarette lighter (optional).....	12
Filling the tank (if applicable).....	13
Filter installation.....	13
Device configuration	14
User interface description.....	14
Features of the device.....	16
How to set the device.....	17
Use	22
Starting treatment.....	22
Stopping treatment.....	22
Use when oxygen is added (optional).....	22
Use of the SD card.....	23
Use of the ModCom or ModCom+ (optional).....	24
Cybersecurity	27
In case of problems	27
Helpful tips.....	27
Device Messages.....	29
Error messages.....	31
Cleaning and maintenance	32
Daily.....	32
Weekly.....	32
Monthly.....	33
Transport of the device	34
Pre-transport precautions.....	34
Air travel.....	34
Technical characteristics	35
Performance of the device.....	35
Humidifier performance.....	35
Conditions of use.....	36
Transport and storing conditions.....	36
Electrical characteristics.....	36
Physical characteristics.....	37
Electromagnetic compatibility.....	37
Special characteristics according to the standard ISO 80601-2-70:2020.....	39
Functional diagram of the internal pneumatic circuit.....	41
Special characteristics according to the standard ISO 80601-2-74.....	42
EC Marking	42
End of life disposal of the device	42

Product description

Please read this manual carefully before using your Néa to understand the usage constraints of the device.

Intended purpose

Néa is Positive Pressure medical device connected by a flexible tube to a mask worn by a patient suffering from obstructive sleep apneas and hypopneas during sleep. The device delivers a continuous flow of air to avoid upper airway obstruction during sleep.

Indications

The Néa device is indicated for the treatment of obstructive sleep apnea and hypopnea syndrome (OSAHS).

Contra-indications

Studies have shown that using positive pressure is contraindicated in certain patients with one of these pre-existing medical conditions :

- Air leak syndrome (pneumothorax with bronchopleural fistula or Severe bullous emphysema)
- Decompensated cardiac insufficiency or hypotension, particularly in case of decreased blood volume or cardiac arrhythmia
- Dehydration
- Tracheotomy.
- Children under 30kg
- Patients who do not breath spontaneously
- Uncooperative or extremely anxious patients
- Reduced consciousness and inability to protect their airway
- Facial trauma or burns
- Patients having recently undergone facial, oesophageal, or gastric surgery
- Copious respiratory secretions
- Severe nausea with vomiting

Furthermore, due to the fact that positive pressure affects the cardiac output in certain heart failure patients, it is recommended that patient blood pressure and heart rate are carefully monitored when starting treatment at an effective pressure. The risks and benefits of treatment by Continuous Positive Airway Pressure must be individually evaluated in such subjects. This evaluation must take into account the fact that the device can be adjusted to deliver pressures up to 20 cmH₂O, and under certain defect conditions, static pressures up to 40 cmH₂O are possible. The device must not be used then, if such pressure level presents a risk to the patient.

Warnings/Precautions

WARNING:

It means that there is a possibility of danger risk of injuries or accident to yourself or others.

- Use this device only with the authorized accessories listed in this manual.
- Use the device only for the purpose recommended in this manual.
- Néa may only be used on medical prescription.
- The device is not intended to provide assistance with vital functions.
- To ensure proper maintenance, and to avoid all possible damages, only qualified and trained personnel is authorized to perform maintenance work or authorized modifications on the device. The user takes full responsibilities for any dysfunction of the device caused by any maintenance done by any unauthorized person.
- Do not begin treatment if you detect an anomaly with the device.
- Never use the device before making sure that the air inlet filter is installed.
- Place the device on a stable horizontal surface in a clean, dry environment. Do not use the device if it is adjacent to or placed on top of another device.
- Do not accidentally or intentionally obstruct the air outlet or any opening in the device or breathing circuit. Do not cover the device or place it too close to a wall. Do not introduce liquids or objects into the air outlet, as they could be propelled into the tube.
- Keep the device and its power supply module away from all sources of water. Only use the device and its accessories if they are dry and in working order.
- Keep the power cord away from any hot surface.
- If additional oxygen is required, scrupulously comply with the instructions and safety instructions relating to the use of oxygen.
- Do not use the device in the presence of flammable vapours and in particular the heated humidifier 'Néa H2O' in the presence of flammable anaesthetic products, either independently or mixed with other gases (risk of explosion).
- Do not leave unnecessary lengths of tube on the bed. They could wrap around your head or neck when you sleep.
- Keep the device away from children and pets.
- Once the device is operating and the mask is in place, check that the device is producing an airflow. If not, remove the mask immediately.
- Never obstruct the mask's exhaust port, which allows air to escape continuously and minimises the rebreathing of carbon dioxide. If the device is operating, the air produced will force the exhaled air through the mask's leak hole. However, if it is not working, there will not be enough fresh air produced in the mask and exhaled air may be rebreathed, which could lead to suffocation in certain circumstances.
- If the device malfunctions and the patient is fitted with a nasal mask, the resistance of the device is low enough to allow the patient to breathe out through the device or simply open his mouth. If the patient is fitted with a face mask, the mask must have an anti-asphyxia valve device.
- Remove the mask in the event of a power cut or device malfunction.
- Any serious incident that occurs in relation to use of the Néa must be communicated to the manufacturer and the competent authority for the Member State in which the user and/or patient is located.
- As this device is an electrical medical device, during its installation, please follow and respect all instructions concerning the electromagnetic compatibility, as indicated in this manual. It must not be used outside its intended electromagnetic environment. Furthermore, the Néa device must not be used if the housing or the cables are damaged.
- It is advisable not to use portable RF communicating devices (including peripherals, such as antenna cables as well as external antennas) closer than 30 cm (12 inches) from all parts of the Néa device. This also includes the specified cables by the manufacturer. Should the opposite happen, the performance of these devices could be altered.
- The equipment must not be covered or positioned in such a way that the operation or performance of the equipment is adversely affected.
- Equipment apnoea (Aflow); equipment hypopnoea (Hflow); and equipment apnoea hypopnoea index (AHLflow) are an estimate provided by sleep apnoea breathing therapy equipment and not diagnostic parameters.

In case the device is equipped with a heated humidifier 'Néa H2O':

- The side cover must be removed and replaced by the humidifier that includes the hot plate and tank.
- Precaution must be taken by the patient while using the tank in order to prevent any risk of water entering the device, which can cause irreversible damage. For this purpose, the device must be placed on a horizontal and stable surface, and not in a tilted position.
- Do not add any product to the water in the tank (essential oils, etc.) as they may have adverse effects.
- The tank should always be emptied before moving it with the device or transporting it.
- The humidifier must not be used with nitric oxide. This could cause the humidifier to malfunction, leading to a serious deterioration in health.
- The use of a humidifier with a gas source (for example, a fan equipped with a compressor/turbine) that heats the gas supplied to the humidifier above a temperature of 35°C may lead to an alteration in the amount of humidification delivered, potentially causing serious deterioration in health.
- The heated humidifier has a plate that may be hot during normal operation, as may the bottom of the tank. Avoid touching them.
- The tank must be cleaned before using it for the first time or after any technical intervention, and then regularly as described in the "Cleaning and Maintenance" paragraph.
- Fill the tank bottom of 'Néa H2O' with water away from the device to prevent water dripping onto it.
- Do not use the device if you notice any leaks from the tank, e.g. due to damage to the seal.
- The heated humidifier must not be used at an ambient temperature above 35°C, as the temperature of the air delivered to the patient could exceed 43°C. This could lead to irritation or burns of the upper airways.
- The addition of a heated humidifier may modify the performance of the device.
- There is a risk of air leakage if the tank or side cover is incorrectly refitted, which could lead to a variation in the pressure applied compared with the prescribed pressure.
- Do not add intermediate parts or accessories to the humidifier that are not listed in the instructions for use for the humidifier or accessory, otherwise the humidifier or accessory may not function correctly and may affect the quality of treatment or injure the patient.
- Do not use the humidifier at altitudes above 2500m or outside a temperature range of +5°C to +35°C with humidifier. Using the humidifier outside this temperature range or above this altitude may affect the quality of treatment or injure the patient.
- To prevent the tube or tube system from becoming disconnected during use, particularly during ambulatory use, only tubes complying with ISO 5367 or ISO 80601-2-74 should be used.
- Covering breathing tubes with a blanket or warming them in an incubator or with an overhead electric heater may affect the quality of treatment or injure the patient.

If the device is equipped with a ModCom or ModCom+ communication module:

- The American HIMA (Health Industry Manufacturers Association) recommends that a minimum separation of 15 cm be maintained between a wireless telephone and a pacemaker in order to avoid any possible interference with the pacemaker. In this context, if the Néa device integrates the ModCom or ModCom+ communication module (optional accessory) then it should be considered as a wireless phone.
- Use the ModCom/ModCom+ communication module only for the purpose indicated in this manual.
- Contact your home healthcare provider if you notice any unexplained changes in the performance of the communication module and if you suspect that this accessory is faulty, degraded or not working properly.
- Do not attempt to open or modify the communication module. Maintenance of this equipment is the responsibility of competent personnel only.
- The communication module complies with electromagnetic compatibility regulations for medical devices. If you use a vital medical device such as a pacemaker, contact your doctor and the manufacturer of this device for further precautions.
- Do not use the communication module in petrol stations, fuel shops, chemical plants and premises containing explosives.

CAUTION :

It means that there is a possibility of material damage to the device or others.

- Place the device in a way that nobody can bump into it or trips over the power cord.
- If the device is placed on the floor, ensure that it is in a place free from dust, bedding, clothing or other objects that may obstruct the air intake.
- After storing or transporting the device, ensure it is used in compliance with the conditions of use specified in this manual.
- Like all medical electrical devices, the device is vulnerable to interference from mobile and portable radiofrequency communication equipment (mobile phones, Wi-Fi...).

- The device has to be controlled to check the proper operation, whenever it is located near AM, FM or broadcast antennas.
- Please do not use the device where radio frequency emission is prohibited.
- The ModCom+ communication module is delivered with the SIM card installed and configured to work with a specific computer server responsible for receiving and managing the data transmitted. Installing another SIM card could cause it to malfunction.

Potential undesirable side effects

Potential undesirable side effects, which in some cases may require temporary discontinuation of treatment, include: unusual chest pain, severe headache, increased dyspnea, dryness of the airways or nose, skin sensitivity, runny or bleeding nose (epistaxis), ear or sinus discomfort or pain, bloating, daytime sleepiness, mood changes, disorientation, irritability, memory loss, eye irritation, sleep disruption, claustrophobia or anxiety, heat-related discomfort (only when using the humidifier), discomfort (reduced mobility due to mask or tubing, device noise) or apnea in case of device failure.

Target patient groups

Néa and its accessories may only be used for the treatment of obstructive sleep apnea-hypopnea syndrome (OSAHS) in patient over 30 kg and with spontaneously breathing.

Intended users

The various potential users of this device are: patients weighing over 30 kg, healthcare professionals and homecare providers.

Patients can receive rapid training from healthcare professionals or homecare providers. This prior training is not essential, but reading this instruction manual is necessary for a correct use of the device.

Environment of use

The Néa is intended for use at home or in a care centre (hospital or clinic). It is also designed to be easily transported and can be used on aircraft (see paragraph "Transport of the device").

It is not suitable to be used in close proximity to CT scanners, MRI devices, RF surgical devices or in transportation vessels (on land, sea or in the air).

Clinical benefits

There is no direct clinical benefit for the patient.

Furthermore, in terms of indirect benefits, regular use of the positive pressure device every night will be accompanied by a reduction in sleepiness, cognitive deficits, deterioration in health, hypertension and metabolic disorders associated with OSAHS.

Essential performance of the device

The device has no essential performance. It was designed to maintain basic safety without maintenance regarding electromagnetic disturbance during the lifetime of the device. However, in case of failure the device has to be repaired by authorized persons who will use original parts only.

Presentation of the system

Néa is available in two models: **Néa Auto** and **Néa Info**.

- ❖ **Néa Info** has a single operating mode: the CPAP mode.
- ❖ **Néa Auto** can operate either in constant mode (CPAP), it then delivers a constant pressure level, or automatic mode (Auto-CPAP) where the pressure changes between a minimum pressure and a maximum pressure depending on the detected respiratory events. When selected, the AUTO-CPAP mode will be activated 5 minutes after starting treatment.

Néa is supplied with the following items:

- Sefam standard tube
- Néa inlet filter
- Sefam power supply
- Patient manual
- Sefam Néa carrying bag
- Sefam SD Card

List of authorized accessories

Néa can be used with the following optional accessories. Contact your Home Healthcare Provider for further information on the accessories available. When using the device, follow the instructions supplied with the accessories.

Mask	Humidification
Breeze Mask Nasal Comfort XS	Néa H2O
Breeze Mask Nasal Comfort S	Néa H2O tank
Breeze Mask Nasal Comfort M	Tube
Breeze Mask Nasal Comfort L	Sefam heated tube
Breeze Mask Facial + S	Sefam Ø 15 mm standard tube
Breeze Mask Facial + M	Ø 22 mm standard tube
Breeze Mask Facial + L	Miscellaneous
Breeze Mask Facial Comfort S	Sefam cigarette cable (24 VDC – max. length 5 m)
Breeze Mask Facial Comfort M	Néa fine inlet filter
Breeze Mask Facial Comfort L	PolyLink effort/ position box
Breeze Mask Zen S	Oximeter 3150 BLE
Breeze Mask Zen M	
Breeze Mask Zen L	
Breeze Mask Pillows	

WARNING:

- Use only the authorized accessories given in the list above or compliant with the standard ISO 17510.
- Only connect the USB authorized cable to the USB connector.
- Use only those accessories which can guarantee the patient's treatment pressure and reduce the rebreathing of CO₂. When a full face mask is necessary, always use a mask which is equipped with an anti-asphyxia valve to maintain spontaneous breathing.
- Use of this equipment adjacent to or stacked with other equipment should be avoided because it could result in improper operation. If such use is necessary, this equipment and the other equipment should be observed to verify that they are operating normally.
- Use of accessories, transducers and cables other than those specified or provided by the manufacturer of this equipment could result in increased electromagnetic emissions or decreased electromagnetic immunity of this equipment and result in improper operation.

- Breathing gas pathways, their parts and accessories are validated for use with specific sleep apnea breathing therapy equipment, here the sleep apnea breathing therapy equipment is the Néa device.
- Incompatible parts or accessories can result in degraded performance.
- The small-bore connectors of the beathing gas pathway used must be compliant with ISO 80369-1:2018.
- Tubes and masks generally have a useful life of one year. For the exact duration, please refer to the accessory manuals.

Views of the device

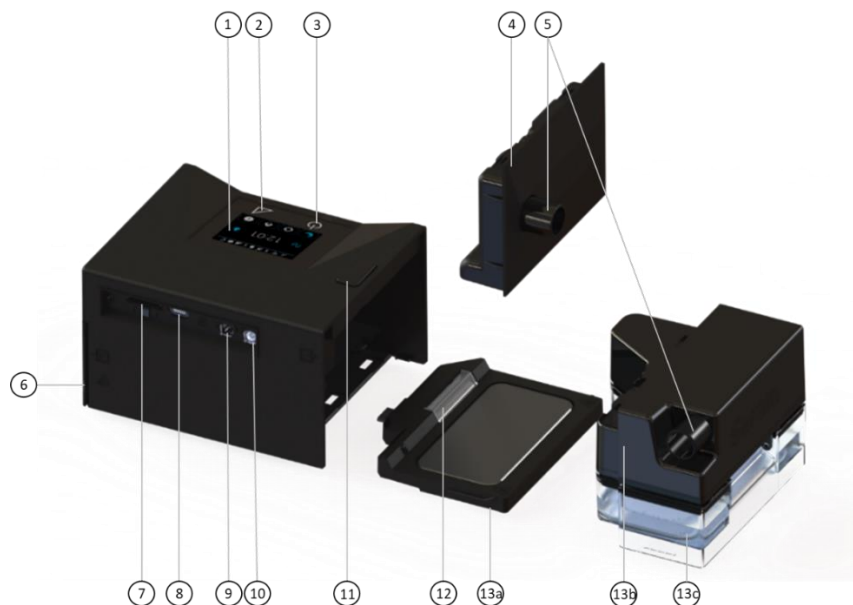





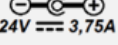

















Figure 1 : Views of the device

1	Touch screen	Allows to view information and access settings.
2	Ramp button	To deactivate or activate the ramp function when the device is in operation.
3	On/off button	Turns the device on or off.
4	Side cover	Used to replace the heated humidifier 'Néa H2O' (13).
5	Air outlet	Connector for connecting the tube.
6	Air inlet grid	Compartment for washable air inlet filter and fine filter (optional)
7	SD card slot	SD card slot.
8	USB-C connector	Allows connection via USB, for use by the doctor or homecare provider.
9	Power connector	Allows the device to be powered by its power supply or by cigarette lighter.
10	Heated tube connector	For connecting the heated tube cable
11	Side cover / tank unlock button	To unlock the side cover or tank and detach it from the device
12	Hot plate unlock button	Button for detaching the heated plate from the device.
13	Heated humidifier 'Néa H2O' :	Used to humidify inhaled air. Once installed, it replaces the side cover (4).
13a	- Hot plate	Base used to heat the water contained in the tank
13b	- Tank cover	Allows to close the tank
13c	- Tank (overmolded)	Element to fill with water

Meaning of symbols

Symbol	Description	Symbol	Description
	Start / standby button.		Ramp button.
	Pay attention to the electrical connections.		Device can no longer be used, dispose separately from household garbage. See paragraph "End of life disposal of the device".
	Class II device.		Type BF device.
	24 V Direct Current power supply		Device composes an RF transmitter, non - ionizing radiation.
	Manufacturer.		Manufacturing date.
	Danger: hot surface.	IP21	Device protected against solid objects of more than 12 mm and against drops of water falling vertically.
	On the tank, this symbol indicates that it is necessary to open the tank and remove its cover before pouring water in from a recipient.		On the tank, this symbol indicates the maximum water level which should not be exceeded in the tank.
UDI	Unique Identifier of device	MD	Medical Device
	On the packaging, this symbol means "Atmospheric pressure limit".		On the packaging, this symbol means "Relative humidity limit".
	On the packaging: this symbol means "Fragile" because the package must be handled with care.		On the packaging: this symbol means "Keep dry" because the package must be protected against moisture and water.
	On the packaging, this symbol means "Temperature limit".		Refer to the user manual.
	Air flow input. Do not clog.		Air flow output. Do not clog.
Rx only	This symbol means "On prescription only". This device may only be sold by a doctor or on a doctor's prescription.		Device complies with the requirements of Regulation 2017/745 on medical devices

Installation

Standard installation

The device must be positioned on a flat and stable surface. It comes with a pre-mounted side cover, and according to the chosen configuration, it can also be delivered with a heated humidifier 'Néa H2O' that replaces the pre-mounted side cover.

1. If you have a humidifier 'Néa H2O', remove the side cover from the device, then attach the humidifier:

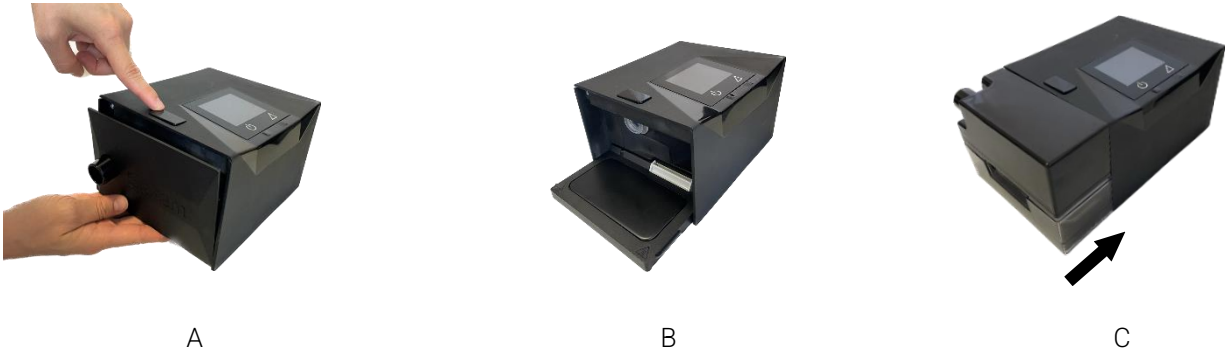

Press the button to unlock the cover (Mark 11 in Figure 1) then pull the cover.

Then place the hot plate in the side part of the device and push it towards the device until you hear a "click".

Place the tank on the hot plate and push the tank against the device until you hear a "click".

2. Connect the breathing tube:

Connect the end of the flexible tube to the outlet connector which is located on the side cover or on the tank cover if the humidifier is attached (Mark 5 in Figure 1).



Without humidifier



With humidifier

If you have a Néa heated tube, insert its power cable lead into the corresponding socket on the device (Mark 10 in Figure 1).

3. Prepare the mask by following the instructions in its operating instructions. Connect the mask to the end of the breathing tube.
4. Plug the power supply cord into the power inlet on the back of the device (Mark 9 in Figure 1) and connect the power supply plug to the power socket.
5. When the device is switched on for the first time, you must select the language, the time zone and set the time (see paragraph "How to set the device").

The next time the device is switched on, the display lights up and the "Néa by Sefam" logo appears.

Then, the standby screen appears a few seconds later, indicating the time.

The device is now ready to use.

Sleep mode (screen off) can be activated in two ways:

- By pressing the "Sleep mode" button 
- After two minutes have passed in standby mode without any touch button action.

To exit sleep mode, press the touchscreen.

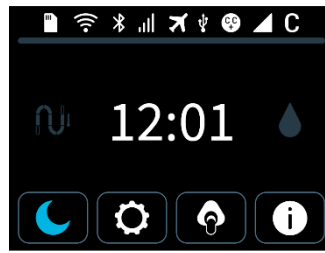

Main screen



Sleep mode

WARNING :

- The Sefam power supply is used to isolate the device from the mains.
- Position the Sefam power supply so that it can be easily disconnected if necessary.
- Risk of air leakage in the event of incorrect installation of the heated humidifier 'Néa H2O', which could cause the pressure applied to vary from the prescribed pressure.
- The heated humidifier 'Néa H2O' is not intended to be used as a transit-operable humidifier.
- Correct fitting and positioning of the mask on the face are essential for the correct operation of this device.
- The humidifier tank may be contaminated by body fluids or exhaled gases.
- It is the responsibility of the organisation responsible for the installation to ensure the compatibility of sleep apnea respiratory therapy equipment with any parts or accessories used to connect it to the patient, before using to.
- It is the responsibility of the organisation responsible for the installation to periodically reassess the treatment setting(s) for therapeutic effectiveness.

Re-installation of the side cover

If the device is equipped with a heated humidifier and you want to replace it with the side cover, you need to unplug the power supply, remove the tank, then disconnect the hot plate and finally replace the side cover:



A

Press the button to unlock the humidifier (Mark 11 in Figure 1) then remove the humidifier.



B

Press and hold the grey button on the hot plate to disconnect it by pulling it outwards.



C

Position the side cover, inserting first the bottom and then the top, until you hear a "click".

Installation with cigarette lighter (optional)

The device can be powered by a cigarette lighter socket using the Sefam cigarette cable (24 VDC) (optional) designed for this purpose. To do this, replace step 4 of the standard installation by the following step:

- Connect the cigarette lighter cable to the power input of the device (Mark 9 in Figure 1) and the other end of the cable directly to the cigarette lighter socket.

CAUTION:

- Use only the 24 V cigarette lighter cable recommended with the device.
- Assure the conformity of the voltage supplied by the cigarette lighter socket.

Filling the tank (if applicable)

1. Unplug the Néa from the power supply or the power socket.
2. To separate the tank from the device, press the button to unlock the tank (Mark 11 in Figure 1) and at the same time, pull the tank away from the device.
3. Put your finger on the clip of the tank cover, then pull it to open the tank cover upwards.
4. Fill the bottom part of the tank with water up to the maximum level mark indicated by **↑ MAX ↑**.
5. Put the upper part back on the base of the tank until you hear a "click" and the clip is properly closed and locked.
6. Place the tank back on the hot plate, with the clip side towards the inside of the device and push it against the device until you hear a "click".
7. Plug the Néa into the power supply or the power socket.

CAUTION:

- Be careful not to exceed the maximum level of the water.
- Fill the tank only with water at room temperature, do not use hot or chilled water.
- It is recommended to use distilled water.
- Do not add any products to the water in the tank (essential oils, etc.) as they may have adverse effects.
- Do not use an alkaline solution (physiological saline).

Filter installation

To operate correctly, the device must be fitted with a reusable air inlet filter that can be washed, and a disposable fine filter (optional):

- The reusable filter must be permanently installed when the device is in operation. It is supplied with the device.
- The fine filter is recommended for people sensitive to fine particles.

To install the filters, follow these steps:



1. Open the air inlet grid at the rear of the device.
2. If necessary, remove the existing filter (see paragraph "Cleaning and Maintenance" for filter cleaning and replacement intervals).
3. Replace the new filter(s) in the compartment, placing the fine filter first, followed by the air inlet filter.
4. Close the air inlet grid.



Device configuration

User interface description

The two touch buttons on the device are used for its operation:

- Start / standby button  : to switch the device on or off.
- Ramp button  : to disable or enable the ramp feature when the device is in use.

The touch-zone display is used to access information and setting menus, and to modify the value of certain parameters, such as:

- Patient treatment settings,
- Recorded compliance data,
- General settings of the device like the brightness and the time.







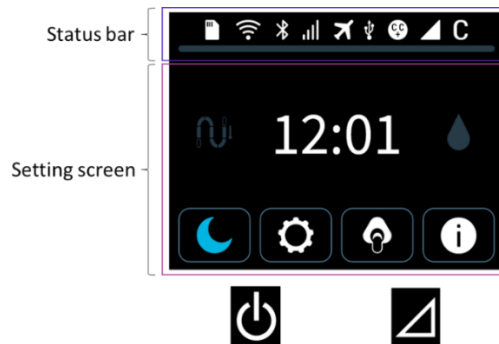





The display can also notify possible problems concerning the device or its accessories.

General organization of display























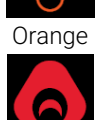

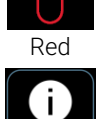











From top to bottom, the display is organized into 2 parts:

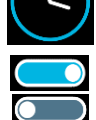

Meaning of symbols displayed

Symbol	Meaning	Symbol	Meaning
Status bar			
	GSM mobile phone network status		Wi-Fi Communication activated
	Flight mode		Oximeter connected
	Comfort Control Plus C.C.+ function activated		Programmable ramp (T RAMP) activated
	SD card inserted Progress bar Messages "Do not remove card" "Transfer in progress"		Intelligent ramp (I RAMP) activated
	SD card missing or incorrectly inserted		Bluetooth connection activated Bluetooth transmission in progress
	USB connection activated		Operation (Only for Néa Auto) C : CPAP A : APAP (Auto-CPAP)

Settings: values, units and symbols displayed

	Sleep mode		Confirm
	Settings		Time zone
	Mask Fit		Language
 Green	Optimal mask leak level		Brightness
 Blue	Moderate mask leak level		Device hour counter
 Orange	Important mask leak level		Setting visualization
 Red	Major mask leak level		Connectivity
	Device information		Heated tube
	Time display		Humidifier
	Pressure level display		Information report on X-day of use
	Home		Cancel
	Treatment		Adjustment of a value
	T Ramp (Programmable ramp)		Increase
	I Ramp (Intelligent ramp)		Decrease
	Intelligent Start (optional)		Changing the screen
	Comfort Control Plus (optional)		Indicates the page of the slide
	Configuration		Error
	Time		Warning
	ON - OFF		

Features of the device

Heated humidification (optional)

The heated humidifier 'Néa H2O' is an accessory designed to warm and add moisture to the air flow delivered to the patient by Néa, for the treatment of Obstructive Sleep Apnea–Hypopnea Syndrome (OSAHS). It is intended for use by adult patients in either the homecare or the hospital environment. The heated humidifier is designed to improve patient comfort.

This function allows to control the power supplied to the hot plate depending on the air flow, and to regulate the heating power to maintain the difference in temperature between the water and the air constant. The device is delivered with an installed side cover and depending on the selected configuration, it may be delivered with a heated humidifier which needs installing. In this case, the side cover must be removed from the device and replaced by the humidifier including the hot plate and the tank. The presence of the humidification system is automatically detected by the device and the heated humidification function starts and stops simultaneously with the device.

Note :

With the humidification level set to 10, the fully filled reservoir provides a minimum of 8 hours' use. Water evaporation is influenced by a number of factors: the environment, leakage rate, patient breathing, etc.



Intelligent Start (optional)

This feature permits the patient to start the treatment automatically at the first breathings in the mask, without using the start / standby button . It can be activated or deactivated by following the instructions of paragraph "How to set the device".

Mask Fit & Go

Before starting the treatment and when the device is in standby mode, the patient can check the air tightness of his/her mask by using the touch button . The level of unintentional leak is displayed and in case of undesired leak, the patient can adjust his/her mask.

Mask unplugged

When the patient removes his mask, the device automatically switches to low power. The device will restore normal power when the mask is reconnected (pressure delivered above 3 cmH₂O) or if the start / standby button  or the ramp button  is pressed. If the mask is unplugged for more than 5 minutes, the compliance session is stopped and recorded, and the device will automatically turn off after 30 minutes.

Comfort Control Plus (optional)

The Comfort Control Plus CC+ is intended to increase the treatment pressure while inhaling and to decrease it while exhaling to make the patient's breathing more comfortable during the treatment. It can be activated during the ramp or the treatment. In both cases, three levels are available in order to get an optimal comfort.

Ramp (optional)

The ramp function makes it possible to gradually increase the pressure to help the patient fall asleep. If it is activated, it starts automatically when the device is switched on (if the ramp time is different than zero). Pressing the ramp button  deactivates (and by pressing again reactivates) this function. There are two types of ramp:

- T RAMP (programmable ramp): you can determine the ramp time
- I RAMP (intelligent ramp): the ramp time is automatically determined by the device.

How to set the device

Some settings may not be accessible on your device. These settings have been blocked by your doctor or healthcare provider or you do not have the accessories: humidifier, heated tube or ModCom/ModCom+.

The settings affected by this blocking are identified by the term "optional".

Menu flowchart :

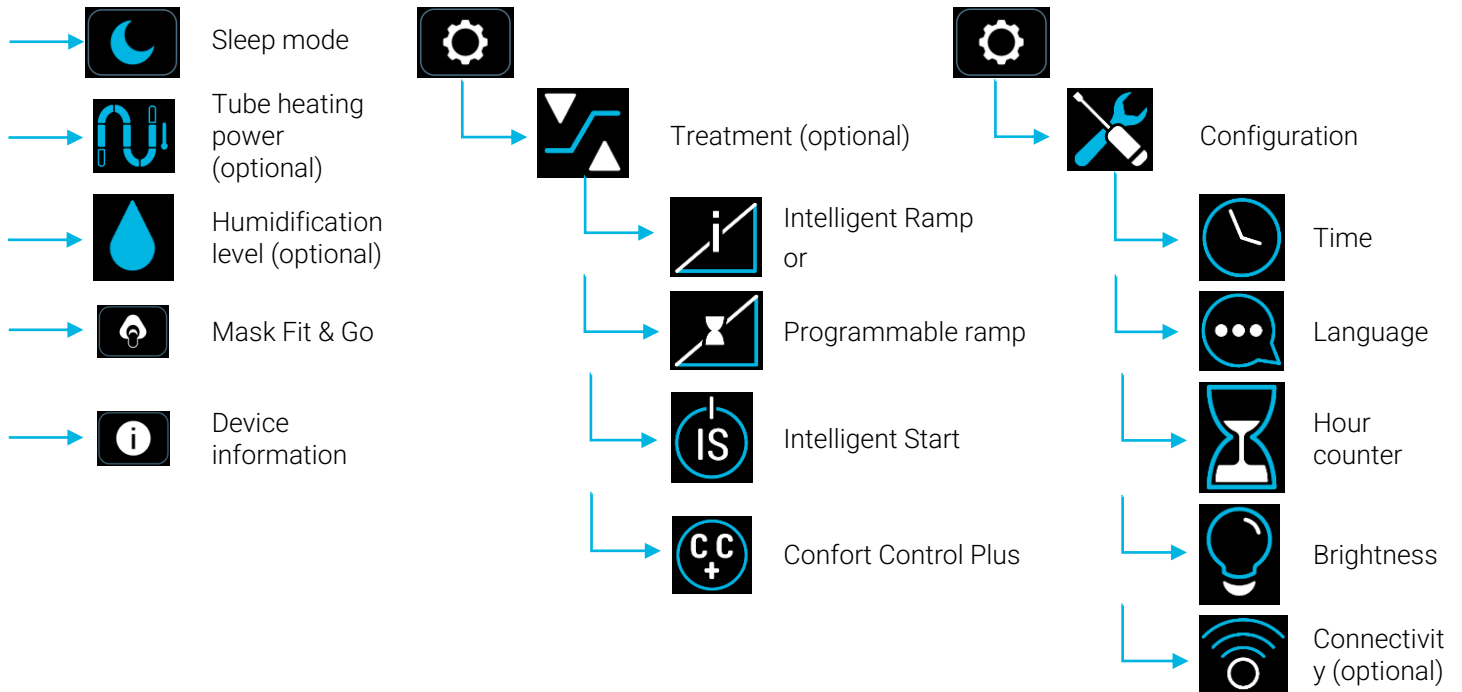

Setting comfort parameters

Tap the touch key



Switch the device in sleep mode.

To reactivate the display, press anywhere on the touchscreen.

Tap the touch key



(the color of the logo differs according to the heating level)

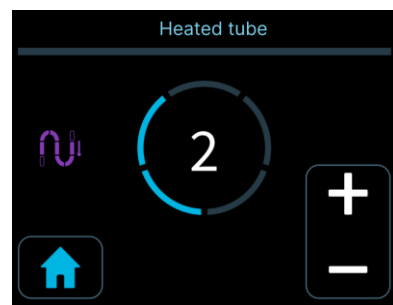

Heated tube heating level (optional): Only with Néa heated tube

You can decrease or increase the displayed value of the heating power

Possible settings:

- OFF (no heating),
- 01 to 05
- AUTO (if a humidifier is also present).

The AUTO mode makes the heating of the heated tube progressive as a function of the heating power level of the heated humidifier

Tap the touch key



(the color of the logo differs according to the heating level)

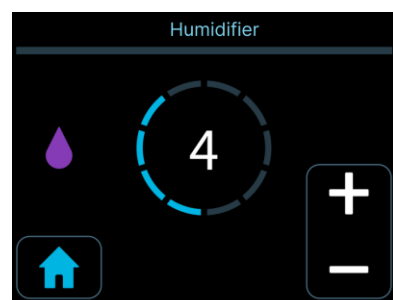

Humidification level (optional): Only with Néa H2O

You can decrease or increase the displayed value of the humidification level.

Possible settings:

- OFF (no humidification),
- 01 to 10

Tap the touch key

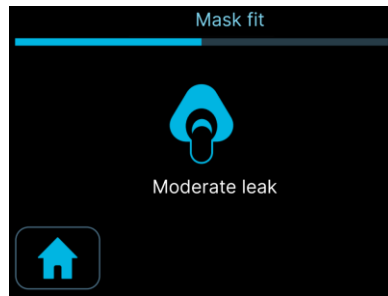

Mask Fit & Go:

Mask tightness check.
Possible displays:

- Optimal
- Moderate leak
- Important leak
- Major leak

In case of undesired leak, readjust your mask.

In settings menu



Tap the touch key



then



or

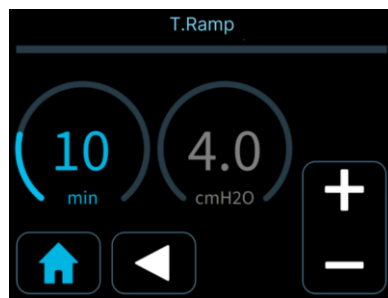

Programmable ramp - T Ramp (optional):

Time setting: 5 to 45 minutes or OFF

Pressure setting:

- from 4 cmH₂O to the maximum pressure adjusted in APAP mode (Néa Auto)
- from 4 cmH₂O to the prescribed pressure in CPAP mode (Néa Info and Néa Auto)

If



Intelligent ramp - I Ramp (optional):

Setting: ON or OFF

Pressure setting:

- from 4 cmH₂O to the maximum pressure adjusted in APAP mode (Néa Auto)
- from 4 cmH₂O to the prescribed pressure in CPAP mode (Néa Info and Néa Auto)

Tap the touch key



then

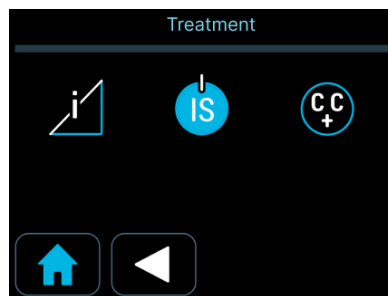

Intelligent Start (optional):

Possible setting:

- ON (blue)
- OFF (black)

Tap the touch key



then

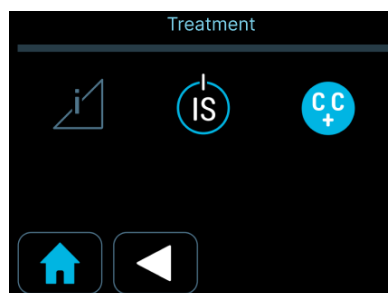

Comfort Control Plus: (optional)

Possible setting:

- ON (blue)
- OFF (black)

Setting general parameters

In settings menu



Tap the touch key



then

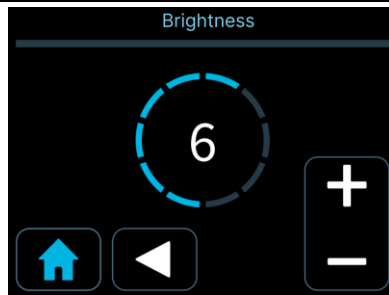

Brightness:

You can decrease or increase the brightness of the display

Possible settings: 01 to 10

Tap the touch key



then

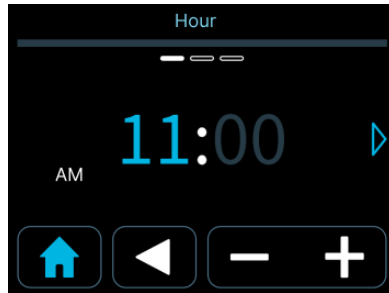

Time:

Set the hour and minutes by selecting the area concerned. Adjust the value with these 2 keys.

Tap the touch to go to the next screen

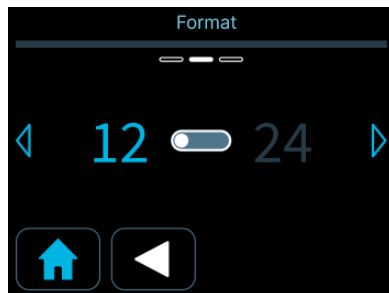

Time format:

Possible setting: 12H or 24H.

Tap the touch to go to the next screen



Time zone selection:

Use the 2 keys to select the time zone.

Tap the touch key



then



Language selection:

Use the 2 keys to select a language.

Tap the touch key



then

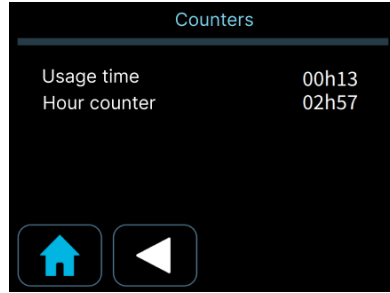

Hour counter:

Display of total compliance time and operating times

Tap the touch key



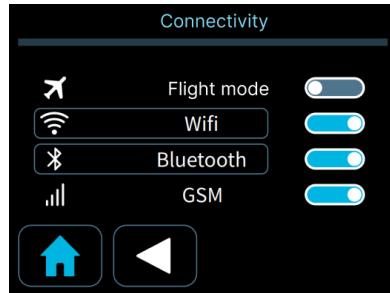

then



Connectivity (optional): Only with communication module

Enabling or disabling connectivity options.

Tap  **Wifi**: Displays the list of WiFi networks memorised in your Néa device.

Tap  **Bluetooth**: Display the names of devices that have already been connected via Bluetooth, as well as the paired device (if applicable).

Device information and visualization of applied parameters

Tap the touch key



Device information

Serial number and version of the ModCom or ModCom+ only if a modem is installed in the device.

Tap the touch  to go to the next screen

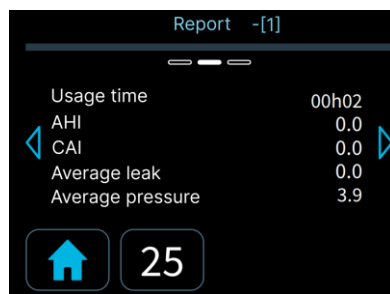

Treatment report

Report [1] displays data for the last 24 hours. For a summary report of the last 1 to 30 days, click on the number next to the home menu.

Note: IAH = IAH_{flow}

Tap the touch  to go to the next screen

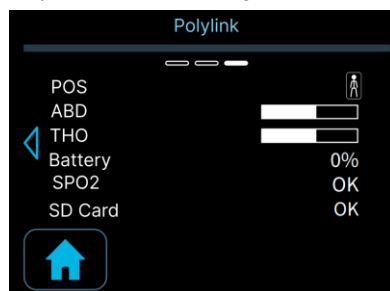

Polylink information (optional): Only with Polylink and device in the treatment process.

Tap the touch key



then

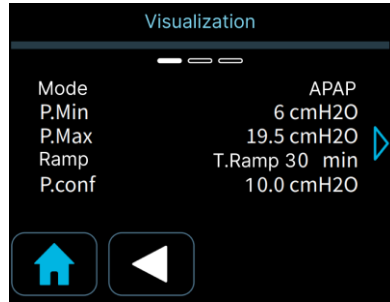

Visualization of settings:

Treatment parameters

Tap the touch  to go to the next screen

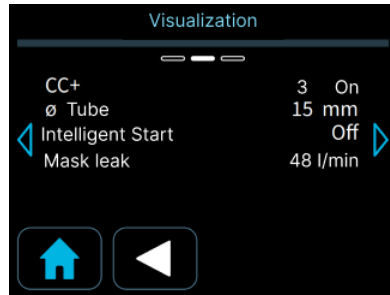

Activated features

Tap the touch  to go to the next screen (optional)

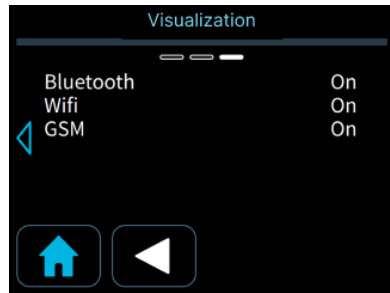

Activated connectivity (optional)

Tap  to exit the menu.

WARNING :



- IAH=IAHflow is an estimate provided by sleep apnoea breathing therapy equipment and not diagnostic parameters

Use

Starting treatment

1. Put on your mask. If the Intelligent Start feature has been activated, the device will start during your first breaths in the mask.



You can also hold down the start / standby button  to begin treatment. Recording of compliance data and of treatment effectiveness begins immediately in the device memory and on the SD card when present.

At this stage, by default, the pressure level is displayed on the screen. You can display the time by pressing the following icon . If you wish to display the pressure level again, press .

2. Then, the display of the device indicates the delivered pressure and if the ramp is enabled (symbol  or  in the status bar).

The displayed symbols indicate which features and accessories are activated (see paragraph "User interface description").

3. If the message " MASK off " appears on the screen, that means your mask is not properly connected.

Reposition it properly to minimize the leak as much as possible, then press the start / standby button  or the ramp button . The device will restore the set pressure and the message will disappear.

4. Lie down and place the breathing tube so that it can follow your movements while you are sleeping.
5. If your device is equipped with a heated humidifier 'Néa H2O', it starts automatically when the device is switched on. You can increase or decrease the humidification level using the touch key , (see paragraph " How to set the device ").

WARNING:

After a power failure, the device will recover the same parameters and operating mode as the ones before the power failure occurred (start / standby).

Stopping treatment

1. Remove the mask.
2. Hold down the start / standby button  to switch off the device. If it is installed, the heated humidifier stops simultaneously.

Use when oxygen is added (optional)

Oxygen can be added to the patient circuit. It is imperative to carefully follow the instructions for use and to take note of the following warnings.

WARNING :

- The oxygen source should be placed at least one meter from the device.
- Oxygen should not be used while smoking or in the presence of an open flame.
- Do not inject oxygen through the device's air inlet and do not inject the oxygen directly at the device's air outlet.
- Oxygen can only be added at the patient end of the breathing tube. Always use an authorized non-return valve when adding oxygen.
- The non-return valve must be placed in-line between the patient breathing hose and the device's outlet connector. It prevents oxygen from flowing from the breathing tube into the device when the device is off. Failure to use the pressure valve may result in a fire hazard.
- The maximum flow rate of oxygen used must not exceed 6 l/min. Using a higher flow rate could result in a fire hazard.
- When using oxygen with this device, the oxygen supply must comply with local regulations for medical oxygen and the oxygen adapter used must comply with ISO 80369-1:2018.
- Scrupulously follow the instructions for starting and stopping treatment.

- Stop the flow of oxygen when the device is not operating. If the oxygen supply is maintained when the device is switched off, the oxygen delivered to the breathing circuit may accumulate in the device and create a fire hazard.

CAUTION:

At a fixed oxygen flow, the concentration of inhaled oxygen varies depending on the settings of pressure, your breathing pattern, type of mask and leakage rate. This applies to most Continuous Positive Airway Pressure devices.

Installation of the non-return valve

When using oxygen, you absolutely must use an authorized non-return valve to prevent the accumulation of oxygen in the device.

This valve must be fitted between the device and the breathing circuit.

This valve must be fitted between the device and the breathing circuit.

Refer to the manufacturer's instructions for installation, cleaning and maintenance of the valve.

Starting and stopping treatment

1. In order to prevent oxygen from entering the device, it is essential that it is in operation and that it generates an air flow before opening the oxygen flow.
2. Similarly, in order to prevent oxygen from entering the device, it is essential to stop the flow of oxygen before switching off the device.

Use of the SD card

The SD card permits to store the most recent compliance data or to update the device settings.

The logo  is displayed if no SD card is present or if it is incorrectly inserted when treatment is in progress.

Inserting the card

Insert the SD card into the reader at the back of the device. The logo  will be displayed if the card is recognised by the device.

Once the card is inserted, the device will read the card and may transfer data to the card. Do not remove the card while the progress bar appears on the screen. The message "Do not remove card" will also appear while the card is being read/write.

Backing up the data

If the data is recorded within the device, the data backup starts automatically when you insert the memory card into the device, turn on the power and stop treatment. Follow the on-screen instructions, do not disconnect the power supply and do not remove the memory card.

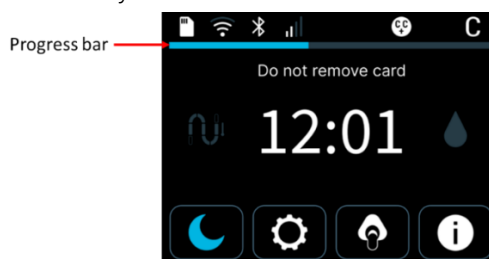

The memory card can also store the signals acquired in real time for about 3 months. For this purpose, a memory card has to be inserted in the device while using it.

Once the data has been saved, you can send the memory card to your service provider or healthcare professional so that they can retrieve the compliance data and analyse it.

CAUTION:

- Only use authorized SD memory cards (the one supplied with the device).
- Do not remove the memory card during processing as data is being recorded in real time.
- If the progress bar appears at the top of the display, this means that settings are being updated or data is being saved. Do not remove the memory card.

Settings update

If the homecare provider has configured the SD card to update device parameters, the update starts automatically when the patient inserts the card for the first time.

Use of the ModCom or ModCom+ (optional)

The ModCom+ communication module is unique in that it can be connected to 3 types of network: WiFi, Bluetooth Low Energy (BLE) and GSM / LTE Cat M1 (cellular network).

The ModCom communication module is unique in that it can be connected to 2 types of network: WiFi and Bluetooth Low Energy (BLE).

In conjunction with Néa devices, they enable:

- Transmission of compliance data stored in the Néa devices to one or more IT servers responsible for receiving and managing the defined data.
- Remote modification of the main settings of Néa devices.
- Sending a system performance indicator every 24 hours.
- Communication with a Smartphone via BLE.

When first connected to the GSM / LTE Cat M1 networks, the ModCom+ communication module searches for available networks.

After each connection to the medical device, Wi-Fi, BLE and GSM technologies  will be displayed in the device's status bar if they are activated.

They will appear in white if they are connected,  i.e. currently being transmitted.

When the ModCom/ModCom+ communication module is installed in the Néa device, the following display appears in the settings menu (patient and providers):

This menu is used to activate or deactivate the communication technologies.

Tap the touch key



then

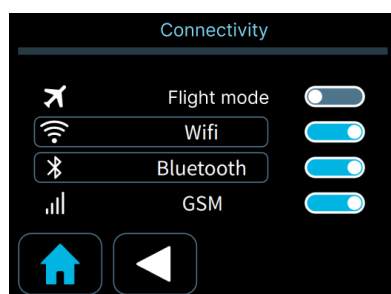

Connectivity : Only with communication module

Tap  **Wifi** : Displays the list of WiFi networks memorised in your Néa device.

Tap  **Bluetooth** : Display the names of devices that have already been connected via Bluetooth, as well as the paired device (if applicable).

First connection to the cellular network (Modcom+ only)

For the cellular network, when searching for a network before sending a session, the network status symbol

 in the status bar of the Néa device changes, alternately passing from four network bars, then three bars, then two and so on (4-3-2, 4-3-2, etc). This stage may last a few minutes, particularly when using for the first time or when changing network (for example when moving the module to another geographical location).

For future transmissions, this stage will only last a few seconds.

When the connection to the cellular network is established, the network status symbol  appear in the status bar of the Néa device, indicating that the ModCom+ communication module is transmitting. It will then revert to grey until the next transmission.

First connection to the BLE network

If an item of equipment is connected to the Néa device via BLE, the BLE connected symbol  is displayed in the status bar. To pair a device, follow the steps below:

Pairing the oximeter

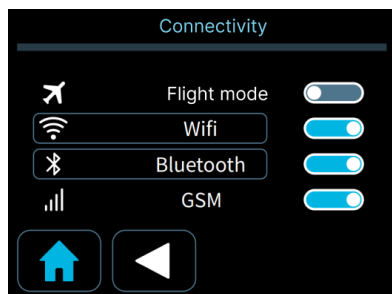

Oximeter - SPO2 (Pulse Oxygen Saturation of haemoglobin)

Tap  Bluetooth to access the Bluetooth pairing menu.

and

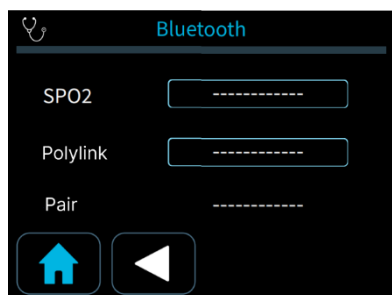

Tap  to start the oximeter search and check that the oximeter is working.

Once the oximeter has been detected, its serial number will appear.

Once the oximeter has been detected, its Bluetooth address will appear.

CAUTION :

Make sure that the Bluetooth address (BDA) matches that of the oximeter you wish to pair.

Pairing PolyLink.

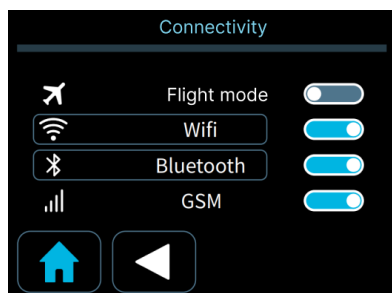

Polylink

Tap  Bluetooth to access the Bluetooth pairing menu.

and

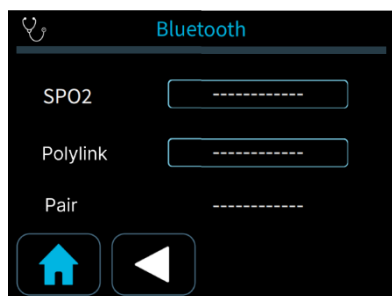

Tap  to start the PolyLink search and check that the PolyLink is working.

Once the PolyLink has been detected, its serial number will appear.

CAUTION :



Make sure that the PolyLink's serial number matches the one you want to pair.

Pairing a smartphone via Sefam Access Lite

To connect to the Néa for the first time via BLE, you need to :

CAUTION :

Make sure you are on the Néa device's main screen when pairing a new device.

1. Select  on your smartphone or tablet to launch the "Sefam Access" application.
2. In the menu at the bottom of the screen, select "Devices" .
3. Select the Néa device.
4. Select the name of the device ending in BLE to which you want to connect.
5. Confirm pairing from the Néa device interface.



Connecting to the Wi-Fi network for the first time

You can connect to the local network using the Sefam Access Lite application.

Connection via Sefam Access Lite

1. Make sure that the symbol is present in the status bar of the Néa device, indicating that Bluetooth communication is active.

If not, activate it in the device settings menu.



2. Select  on your smartphone or tablet to launch the " Sefam Access Lite" application.
3. In the menu at the bottom of the screen, select "Devices" .
4. Select the Néa device.
5. Accept the Bluetooth authorisations.
6. Select the name of the device you wish to connect to.
7. On the device details page, press the "Configure" button.
8. Choose the type of configuration you want to use:

Automatic configuration

- Press the WPS button on your Wi-Fi router.
- You then have approximately two minutes to send the WPS configuration to the Néa device by selecting "Connect via WPS" on the application.
- When the information has been successfully sent to the device, the message "The configuration request has been successfully sent to the Néa device" will appear on the screen.

Manual configuration (with Wi-Fi available in the list)

- The application searches for available networks within range of your tablet or smartphone.
- Select your network when it appears on the application.
- Enter your "Password" in the field that appears on the screen.
- Send the configuration to the Néa device by selecting the "Connect to Wi-Fi" button on the application. The Wi-Fi module will then connect to the network.
- When the information has been successfully sent to the device, the message "The configuration request has been successfully sent to the device" will appear on the screen.

If the connection to the local network is correct, the symbol  appears for a few seconds in the status bar of the Néa device, showing that the Wi-Fi module is functional, and then turns grey .

Sefam Access also sends a confirmation if the module is properly connected.

Cybersecurity

To ensure safe use and to protect your device and your data, we recommend that you :

- Only give access to your device to persons you trust (medical team, service provider, etc.),
- Only use the original SD card with the device, or an SD card supplied by the service provider,
- Restrict the USB connection available on the device to the medical team; do not connect unauthorized devices to this connection.

If your device is equipped with a communication module (ModCom or ModCom+), never set up a connection to a public Wi-Fi network, or to a Wi-Fi network that is not password-protected, and always ensure that the password is strong and remains confidential.









In case of problems

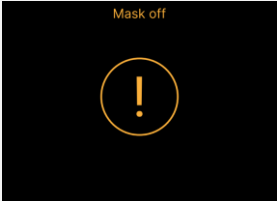

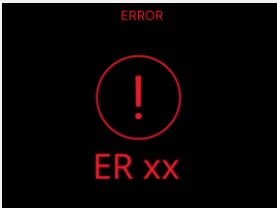

Helpful tips

Problem	Possible cause	Suggestion
Your nose is cold	Room temperature is too low.	Increase the room temperature.
	The air delivered is too cold.	Ask your Home Care Provider to provide you with a Néa heated tube.
Running nose.	Reaction from air flow and pressure.	Contact the medical-technical support or your doctor.
Your nose or throat is dry or irritated.	The air is too dry	Use the humidifier when device equipped with one. Increase the humidification level (see paragraph " How to set the device ").
	Lack of water in tank (if included).	Check the water level in the tank. If necessary, fill it (see paragraph "Filling the tank").
Pain in the nose, sinus or ears.	Sinus infection or nasal congestion.	Contact your doctor immediately.
Redness of your skin in contact with the mask.	The headgear is too tight or it has the wrong size.	Adjust the headgear. Contact your doctor or Home Care Provider to try different sizes.
	Allergic reaction to mask components	Stop using the mask. Contact your doctor or the Home Care Provider.
Dryness or irritation of eyes.	Air leak around the mask.	Reposition the mask. Ask your doctor or Home Care Provider to try different sizes of masks.
The device delivers air which is too hot.	Air inlet filters are dirty.	Clean or replace the air inlet filters (see paragraph "Cleaning and Maintenance").
	The air inlet is clogged.	Keep all linen and clothing away from the device.
	The room temperature is too high.	Lower the room thermostat. Make sure the device is away from sources of heat. Unplug the Néa heated tube (if present).
The device does not deliver the correct pressure on the display.	A ramp is activated.	Check that the ramp indicator is displayed. If necessary, deactivate the ramp function (see paragraph " How to set the device ").
	The selected ramp does not suit you.	Contact your Home Care Provider.

Problem	Possible cause	Suggestion
The device seems to be disturbed and not functioning properly.	Too much electro-magnetic disturbance.	Keep the device away from sources of interference such as halogen lamps, mobile phones, etc.
Discomfort due to excessive pressure sensation.	Pressure of the device. The device is set in Auto-CPAP mode.	Adjustment of nasal pressure takes some time. Use the I Ramp to help you fall asleep (see paragraph "Features of the device"). Relax and breathe slowly through your nose. The pressure level has been prescribed by your doctor, it can only be changed by medical prescription. If you feel that the pressure from the device has changed, contact your Home Care Provider to have it checked.
Re-occurrence of symptoms of sleep apnea syndrome.	The device is not set on the correct pressure or is not working properly. Your physical condition or pressure needs have changed.	Ask the Home Care Provider to check how it operates. Contact your doctor.
The device does not turn on (no display).	The power supply is not connected properly. Absence of mains. The internal fuse of the device is defective.	Check the connections between the device, the power supply and the mains plug. Use another device (e.g., lamp, radio etc.) to check if the electrical outlet is working. Contact your Home Care Provider.
White deposits appear in the tank.	These are traces of lime scale from tap water.	Rub the traces with a sponge and a mild detergent. Soak the tank in a solution with water and washing-up liquid, soap or white vinegar (see paragraph "Cleaning and Maintenance"). Rinse thoroughly with tap water. Wipe the outer part with a clean cloth.
Water droplets appear in the breathing tube, the Néa heated tube or the mask.	A few drops of water are normal, especially in winter. The water level is too high in the tank (if included). Condensation of water vapor is excessive.	Decrease the humidification level (see paragraph "How to set the device"). Check that the water level in the tank does not exceed the maximum, otherwise empty the excess water. Put the breathing tube under a blanket.
Water was spilled into the device.		Unplug the device and allow it to dry for at least 24 hours. Reconnect the device and make sure it is working properly.
The temperature of the heated tube is too low.	The heat level of the tube is set on OFF.	Set the heat level between 01 and 05 (see paragraph "How to set the device").
The humidifier does not appear to heat the water.	The humidification level is set on OFF.	Set the humidification level between 01 and 10 (see paragraph "How to set the device").

Device Messages

Displayed message	Possible cause	Suggested solution
	<p>The mask is disconnected.</p>	<p>Check the connection between the mask, the breathing tube and the device. This message disappears once you breathe into your properly reconnected mask or tap the button </p>
 <p>blinks on screen</p>	<p>The device detected an operating error in the heated humidifier.</p>	<p>Check that the heated humidifier is properly installed in the device (see paragraph "Standard installation"). The device is operating without the heated humidification function. Unplug the device from all power sources. Plug it in again and turn it on. If the problem persists, contact your Home Care Provider.</p>
 <p>blinks on screen</p>	<p>The device has detected a malfunction of the heated tube.</p>	<p>The device is operating without using the function of the heated tube. Check the tube connections to the device. Unplug the device from all power sources. Plug it in again and turn it on. If the problem persists, contact Technical Support Service.</p>
<p>The  symbol blinks on the status bar display.</p>	<p>The SD card is locked. The SD card is 90% full, or more. SD card error.</p>	<p>Unlock the SD card and reinsert it into the SD card slot. If the symbol continues to blink, contact your Home Care Provider.</p>
<p>The symbol  blinks on the status bar display.</p>	<p>The SD card is either not inserted or not properly inserted in the device when the treatment is in progress.</p>	<p>Insert the SD card properly into the SD card slot. If the symbol continues to blink, contact your Home Care Provider.</p>
 <p>Error screen appears (xx = 2 digits).</p>	<p>The unit detected an operating error.</p>	<p>Refer to the paragraph "Error messages"</p>
<p>The symbol  is not present in the status bar.</p>	<p>The ModCom+ communication module is not installed or incorrectly inserted in the device. The communication module connection is not activated. Communication module software problem.</p>	<p>Contact your homecare provider. Check that the communication module connection is active in the device settings menu, if not activate it. Disconnect the Néa device from the power supply. Plug it in again. If the problem persists, contact your Home Care Provider.</p>

<p>The symbol  does not stop scanning during data transmission.</p>	<p>The connection to the cellular network is not correct.</p>	<p>Follow the instructions in the "Use" section. If the problem persists, contact your homecare provider.</p>
<p>The symbol  does not appear in the status bar.</p>	<p>The module is not installed or is incorrectly inserted in the Néa device. The Wi-Fi connection is not activated.</p>	<p>Contact your homecare provider. Check that the module is activated in the Néa settings menu, otherwise activate it. If the problem persists, contact your Homecare Provider.</p>
<p>The symbol  remains greyed out during data transmission.</p>	<p>The connection to the local network is not correct. Wi-Fi communication is not active.</p>	<p>Follow the instructions in the section entitled "Connecting to your Wi-Fi network for the first time". Disconnect and reconnect your Wi-Fi router. If the problem persists, contact your homecare provider.</p>
<p>The Wifi symbol is blinking.</p>	<p>Attempt to configure a WiFi network has failed</p>	<p>Try configuring the Wifi again by checking the password and the Internet connection on your module. If the problem persists, contact your Home care provider.</p>
<p>The symbol  appears for a long time</p>	<p>Compliance data relates to a long period.</p>	<p>Leave the Néa device on standby for a sufficient period of time. If the problem persists, contact your homecare provider.</p>
<p>The symbol  is not in the status bar.</p>	<p>Bluetooth communication is not activated</p>	<p>Check in the settings menu that Bluetooth is activated. If the problem persists, contact your Homecare Provider.</p>
<p>Unable to connect a smartphone or an oximeter or Polylink measurement device.</p>	<p>BLE (Bluetooth Low Energy) communication is not activated. The smartphone has not authorised localisation when the application is active.</p>	<p>Check that BLE communication is enabled in the Néa device settings menu. If not, activate it. See "Use" section. If the problem persists, contact your homecare provider.</p>
<p>The communication module seems disturbed and is not working properly.</p>	<p>Excessive electromagnetic interference.</p>	<p>Keep the Néa device away from sources of interference such as halogen lights, mobile phones, etc.</p>

Error messages

Code	Description	Corrective action
ER01	Problem with patient settings.	Unplug the device from all power supply. Plug it in again. If the error persists, return the device to Technical Support service.
ER02	High temperature in the motor	Unplug the device from all power supply. Allow it to cool down and plug it in again carefully following the instructions from the patient manual. If the error persists, return the device to Technical Support service.
ER03	Motor voltage problem	
ER04	High pressure	Unplug the device from all power supply. Plug it in again.
ER05	Serial number error	If the error persists, return the device to Technical Support service.
ER06	Checksum code error.	
ER07	Blower problem.	Unplug the device from all power supply. Verify that there is no object in the air outlet. Plug the device in again. If the error persists, return the device to Technical Support service.
ER08	Voltage level problem	
ER09	Internal memory error	
ER10	Device set-up problem	
ER11	High motor current consumption	
ER12	Device memory is empty.	Unplug the device from all power supply. Plug it in again. If the error persists, return the device to Technical Support service.
ER13	Communication error on the I ² C bus.	
ER14	Communication error on QSPI bus	
ER15	Internal memory error	

Notes :

- When an error is detected, the device goes in standby mode (except for special cases) making access to different menus impossible.

Cleaning and maintenance

For more details on how to maintain the accessories, refer to the instructions for use for the mask, breathing circuit, heated tube and communicating accessory used.

WARNING:

Unplug the device from the power supply. Always remove the breathing tube and the tank from the device before cleaning.

CAUTION:

- For cleaning, only use materials suited for this purpose.
- Do not use aggressive detergent, scouring sponge or hard bristle brush.

Daily

Tank (if humidifier 'Néa H2O' is installed)

- Remove the tank:
 - To remove the tank from the device, press the button to unlock the tank (Mark 11 in Figure 1) and at the same time, pull the tank using the integrated handle.
 - Put the tank away from the device and pull the opening clip upwards to release the upper part of the tank. Empty the water if any.
- Rinse with clean water.
- Allow to dry by draining, away from the sun.
- Re-install the tank, once it is dry.
 - Fill the bottom part of the tank, then press down on the upper part to close the tank and lock it.
 - Place the tank back on the hot plate, hinge side towards the inside of the device, and push it against the device until you hear a "click".

Weekly

Tank (if humidifier 'Néa H2O' is installed)

- Remove the tank:
 - To remove the tank from the device, press the button to unlock the tank (Mark 11 in Figure 1) and at the same time, pull the tank using the integrated handle.
 - Put the tank away from the device and pull the opening clip upwards to release the upper part of the tank. Empty the water if any.
- Clean the different parts of the tank with warm water and a mild detergent (e.g. using 3 drops of dishwashing liquid diluted in water).
- Rinse thoroughly with water to remove any trace of detergent.
- Allow to dry by draining, away from the sun.
- Re-install the tank, once it is dry.
 - Fill the bottom part of the tank, then press down on the upper part to close the tank and lock it.
 - Place the tank back on the hot plate, hinge side towards the inside of the device, and push it against the device until you hear a "click".

Notes:

- Do not leave stagnant water in the tank in order to prevent the development of micro-organisms.

Washable filter (Air inlet filter)

- Open the air inlet grid (Mark 6 in Figure 1).
- Pull the filter towards you to remove it.
- Wash the filter with lukewarm water and a mild detergent (e.g. using a drop of dishwashing liquid diluted in water).
- Rinse thoroughly to remove any trace of detergent.
- Drying the filter: press the filter in a clean absorbent cloth, then, let it dry totally away from the sun.
- Once dried, place the filter at the back of the device and close the air inlet grid. Do not use a partially dry filter.
- It is recommended to change the washable filter every 6 months.

Monthly

Device

- Clean the outside of the device with a damp cloth (rag, paper towel) sprinkled with a little water and a drop of mild detergent.
- Remove traces of detergent by repeating this procedure with a new cloth, (rag, paper towel) slightly moistened with only water.
- Wipe the device completely dry with a dry cloth (rag, paper towel).

Fine filter (*the finer of the two filters*)

- The optional fine filter cannot be washed. It must be changed once a month or more, if it is visibly dirty.
- Change filters as soon as they are torn or stained.

Tank (if humidifier 'Néa H2O' is installed)

- Once the tank has been cleaned, the patient can let it soak for 15 minutes in a solution of water and washing-up liquid, soap or white vinegar.
- Rinse thoroughly with water to remove any trace of washing-up liquid/soap/vinegar.
- Allow to dry by draining, away from the sun.
- When the tank has been removed and emptied, the hot plate can be cleaned by following same cleaning procedure as the device. Reinstall it once it is dry.
- Put the tank back in place.
 - Fill the tank, then press down on the upper part to close the tank and lock it.
 - Place the tank back on the hot plate, hinge side towards the inside of the device, and push it against the device until you hear a "click".

Notes:

- The different parts of the tank can also be cleaned in a dishwasher (maximum 70 ° C).
- Do not leave stagnant water in the tank in order to prevent the development of micro-organisms.

WARNING:

- Check if the hot plate is properly dried before plugging the device.
- Never use the device without making sure that the air inlet filter is present.
- Do not use spray detergent. Harmful residues could enter and remain in the air outlet, the air inlet filter or inside of the device, which could cause air way irritation.
- Never use concentrated bleach higher than 0.1%.
- The reservoir is the only part of the gas pathways passing through the humidifier that is likely to be contaminated by bodily fluids or contaminated substances carried by exhaled gases, both under normal conditions and in the event of a first fault.

Transport of the device

Pre-transport precautions

Unplug the power module and disconnect all accessories from the device. Store the device and accessories in the carry bag.

If your device is equipped with a humidifier, press the button to unlock the tank and at the same time, slide the tank outwards. Then make sure there's no water in the tank. Then remove the hot plate. Then place it and the tank in the compartment provided in the travel bag.

Replace the side cover on the device, pressing it down until you hear a "click". Stow the unit in the bag.

CAUTION:

It is absolutely necessary that you empty the tank before moving or transporting the device, in order to prevent any risk of water entering the device, which can cause irreversible damage.

Air travel

Néa is designed to travel easily and can be used on aircraft without humidifier.

If you are travelling by plane, it is advisable to take this manual with you to facilitate check-in and security formalities at airports.

You can take the device and its accessories with you as hand luggage in their carry-on bag. However, it is advisable to protect them well in a rigid case if they have to travel in the luggage hold.

If you are travelling to a country where the voltage is different from that normally used, it may be necessary to bring a different power cord or an adapter to connect your device to the electrical sockets in that country.

WARNING:

- The heated humidifier 'Néa H2O' is not intended to be used as a transit-operable humidifier

Technical characteristics

Performance of the device

Pressure range:	4 cmH ₂ O to 20 cmH ₂ O Adjustable by steps of 0.5 cmH ₂ O
Maximum pressure at the patient-side connection port in the first default condition:	40 cmH ₂ O
Maximum adjustable pressure:	20 cmH ₂ O
Duration of ramp:	0 to 45 minutes ± 1 minute Adjustable in 5 minutes steps
Sound pressure level measured according to standard ISO 80601-2-70:2020:	26,5 dBA with side cover 27,0 dBA with humidifier
Patient-side connection port:	conical connector 22 mm in diameter
Expected life of the device:	5 years (for a typical use of 8 hours a day)
Air inlet filters:	Optional high-efficiency filter, disposable fabric. HEPA filter, which is 90% effective for particles > 3 microns.

Values determined under ATPD (Ambient Temperature and Pressure, Hygrometry) conditions.

Time required for the device to warm from the minimum storage temperature between uses until it is ready for its intended use when the ambient temperature is 20°C:	At least one hour
Time required for the device to cool from the maximum storage temperature between uses until it is ready for its intended use when the ambient temperature is 20°C:	At least one hour

Humidifier performance

Use specification:	Category 2
Humidification rate:	> 10mgH ₂ O/l at the maximum setting for a leakage rate < 45 l/min.
Heating time:	45 minutes
Pressure drop depending on flow:	0,3 cmH ₂ O at 1 l/sec
Tank compliance:	9,75 ml / kPa (tank empty) 6,92 ml / kPa (tank full)
Maximum operating pressure:	20 cmH ₂ O
Maximum gas temperature coming from the respiratory circuit:	43°C (109°F)
Static Temperature Stability (for a leakage rate of 15 to 45 l/min)	±2°C

The humidification rate includes a measurement uncertainty of 2.7%.

Values determined under ATPD (Ambient Temperature and Pressure, Hygrometry) conditions.

Mask Pressure cmH ₂ O	Nominal system output mg/L	
	Setting 1 (min)	Setting 10 (max) ¹
4	>4	>10
20	>4	>10

¹Humidifier performance meets ISO 80601-2-74 : 2021 performance > 10 mg/L tested at 15°C to 35°C and relative humidity > 15%

Conditions of use

Pressure range:	700 hPa to 1060 hPa
Temperature:	+5°C to +40°C (+41°F to +104°F) with side cover +5°C to +35°C (+41°F to +95°F) with humidifier
Relative humidity:	Between 15 % and 90 % without condensation
Altitude range:	Approximately 0 – 2 500 m (0- 8200ft)
Maximum temperature of applied parts:	51°C (or 124°F)
Time of contact of the patient with applied parts:	< 1 minute

Transport and storing conditions

Pressure range:	700 hPa to 1060 hPa
Temperature:	-25°C to +70°C (-77°F to +158°F)
Relative humidity:	Up to 90 % without condensation

Electrical characteristics

Device

Input voltage:	24,0 V \pm 20 %
Maximum power consumption:	75 W during a mask disconnection
Current consumption at 20 cmH ₂ O with a 4-mm leak:	0,42 A (minimum configuration: Néa only) 1,99 A (maximum configuration: with humidifier set to 10 and heated tube set to 05)

Radio specifications

RF emission type (optional Néa ModCom or Modcom+) :	Bluetooth LE
Frequency band:	2340 à 2483 MHz (ISM band)
Maximum power:	+ 9 dBm max.
RF emission type (optional Néa Modcom+) :	GSM/FDD-LTE
Frequency band:	850/900/1800/1900 MHz Bands 1-5, 8, 12-14, 18-20, 25-28, 66, 71, 85
Maximum power:	+ 33 dBm max.
RF emission type (optional Néa ModCom ou Modcom+) :	Wi-Fi 802.11b/g/n
Frequency band:	2412 à 2484 MHz (ISM band)
Maximum power:	+ 19,5 dBm max.

Power supply

Power supply class II:	
Input voltage:	100 – 240 VAC, 50 - 60 Hz
Power supply provided:	MDS-090BAS24 A (outlet depending on the country)
Input current:	2 - 1 A
Output voltage:	24 V

WARNING:

- Use only the plug-in power supply provided with the device.
- The power supply is not intended to be repaired. In case of a breakdown, please contact your home care provider for a replacement.
- Use of other power supplies or cables than those specified may adversely affect electromagnetic performance.
- Do not use the unit, cables, power supply or accessories if they are damaged.
- The 24 VDC input is protected against voltage reversals.

Physical characteristics

Dimensions (L x W x H):	145 x 197 x 106 mm with side cover (5,7 x 7,8 x 4,2inch) 145 x 235 x 106 mm with humidifier (5,7 x 9,3 x 4,2inch)
Carrying bag dimensions (L x W x H):	300 x 245 x 145 mm (11,8 x 9,6 x 5,7 inch)
Carrying case dimensions (L x W x H):	315 x 260 x 160 mm (12,4 x 10,2 x 6,3 inch)
Weight (without power supply):	1,0 kg with side cover (2,2 lbs) 1,3 kg with humidifier (2,9 lbs)
Power supply weight:	0,5 kg (1,1 lbs)
Operational volume (minimum volume of gas in the tank):	532 ml
Usable volume of water in tank:	340 ml
Maximum liquid level:	Indicated by ↑ MAX ↑ on tank

Electromagnetic compatibility

The Néa medical device meets all electromagnetic compatibility (EMC) requirements for home healthcare and professional healthcare environments in accordance with IEC 60601-1-2:2020.

Electromagnetic emissions	Compliance	Electromagnetic environment guidance
RF emissions CISPR 11	Group 1	The device uses RF energy only for its internal function. Therefore, its RF emissions are very low and are not likely to cause any interference in nearby electronic equipment.
RF emissions CISPR 11	Class B	The device is suitable for use in locations in residential environments and in establishments directly connected to a low voltage power supply network which supplies buildings used for domestic purposes.
Harmonic emissions IEC 61000-3-2	Class A	
Voltage fluctuations/Flicker emissions IEC 61000-3-3	Complies	
Emission Of Radio Frequency Energy RTCA/DO-160G Section 21	Category M	This device is suitable for use in the cabin of airliners.

Electromagnetic immunity	Compliance level	Electromagnetic environment guidance
Perturbations conduites, induites par les champs RF IEC 61000-4-6	3 V _{RMS} . between 150 KHz and 80 MHz 6 V _{RMS} . In ISM bands and amateur radio bands ^a between 150 KHz and 80 MHz 80 % AM à 1 kHz	Portable and mobile RF communications equipment should not be used closer to any part of Néa, including cables, than the recommended separation distance calculated based on the equation applicable to the transmitter frequency. Recommended separation distance $d = 1,2 \sqrt{P}$
Radiated RF electromagnetic fields IEC 61000-4-3	10 V/m de 80 MHz at 6 GHz ^b 80% AM at 1 kHz	Recommended separation distance $d = 1,2 \sqrt{P}$ 80 MHz to 800 MHz $d = 2,3 \sqrt{P}$ 800 MHz to 2,5 GHz
Proximity fields emitted by RF wireless communication equipment IEC 61000-4-3	27 V/m 380-390 MHz PM 18 Hz 28 V/m 430-470 MHz FM ± 5 KHz sinus 1 KHz	Recommended separation distance $d = 0.3 \text{ m}$

	9 V/m 704-787 MHz PM 217 Hz 28 V/m 800-960 MHz PM 18 Hz 28 V/m 1700-1990 MHz PM 217 Hz 28 V/m 2400-2570 MHz PM 217 Hz 9 V/m 5100-5800 MHz PM 217 Hz	P is the power of the transmitter in Watts (W) and d is the recommended separation distance in meters (m)
Electrostatic discharge IEC 61000-4-2	± 8 kV contact ± 2 kV, ± 4 kV, ± 8 kV, ± 15 kV air	Floors should be wood, concrete or ceramic tile. If floors are covered with synthetic material, the relative humidity should be at least 30 %.
Electrical fast transient/burst IEC 61000-4-4	± 2 kV for power supply lines 100 kHz repetition frequency ± 1 kV for input / output lines 100 kHz repetition frequency	Mains power quality should be that of a typical residential, commercial or hospital environment.
Line-to-line surges IEC 61000-4-5	± 0.5 kV, ± 1 kV	Mains power quality should be that of a typical residential, commercial or hospital environment.
Line-to-ground surges IEC 61000-4-5	± 0.5 kV, ± 1 kV, ± 2 kV for power supply lines ± 2 kV for input / output lines	Mains power quality should be that of a typical residential, commercial or hospital environment.
Voltage dips IEC 61000-4-11	0 % U_T ; 0,5 cycle A 0°, 45°, 90°, 135°, 180°, 225°, 270° and 315° 0 % U_T ; 1 cycle et 70 % U_T ; 25/30 cycles Single-phase : à 0°	Mains power quality should be that of a typical residential, commercial or hospital environment. If the user of the device requires continued operation during power mains interruptions, it is recommended that the device be powered from an uninterruptible power supply or a battery.
Voltage short interruptions IEC 61000-4-11	0 % U_T ; 250/300 cycles	
Magnetic fields in the 50 Hz and 60 Hz power supply frequencies IEC 61000-4-8	30 A/m at 50 Hz and at 60 Hz	Power frequency magnetic fields should be at levels characteristic of a typical residential, commercial or hospital environment.
Proximity fields between 9 kHz and 13,56 MHz IEC 61000-4-39	8 A/m at 30 kHz CW 65 A/m at 134,2 kHz PM 2,1 kHz 7,5 A/m at 13,56 MHz PM 50KHz	Recommended separation distance d = 0.15 m

Notes :

- U_T is the mains voltage before the test level is applied.
- These guidelines may not apply to all situations. Electromagnetic propagation depends on absorption and reflection from structures, objects and people.

Notes:

^a The ISM bands (industrial, scientific and medical) between 0,15 MHz and 80 MHz are: 6,765 MHz to 6,795 MHz; 13,553 MHz to 13,567 MHz; 26,957 MHz to 27,283 MHz; and 40,66 MHz to 40,70 MHz. The amateur radio bands between 0,15 MHz and 80 MHz are: 1,8 MHz to 2,0 MHz, 3,5 MHz to 4,0 MHz, 5,3 MHz to 5,4 MHz, 7 MHz to 7,3 MHz, 10,1 MHz to 10,15 MHz, 14 MHz to 14,2 MHz, 18,07 MHz to 18,17 MHz, 21,0 MHz to 21,4 MHz, 24,89 MHz to 24,99 MHz, 28,0 MHz to 29,7 MHz and 50,0 MHz to 54,0 MHz.

^b Due to the presence of a wireless transceiver in Néa, the radiated RF electromagnetic field immunity tests are performed between 80MHz and 6000 MHz rather than between 80 MHz and 2700 MHz.

Special characteristics according to the standard ISO 80601-2-70:2020

Sound pressure level measured according to ISO 80601-2-70

With side cover:

NOISE EMISSIONS VALUES DECLARED DISSOCIATED	
In accordance with ISO 4871	
A-weighted sound power level, LWAd (Reference 1pW), in decibels	34,5
Uncertainty KWA in decibels	3
A-weighted emission sound pressure level, LPAd (Reference 20µPa) at 1m, in decibels	26,5
Uncertainty KpA in decibels	3

Values obtained in accordance with the noise test code given in standard ISO 3744:2010, with the application of the basic standard ISO 80601-2-70.

NOTE - The sum of a measured value and the associated uncertainty represents an upper limit of the range in which the measured values are likely to be.

With heated humidifier 'Néa H2O':

NOISE EMISSIONS VALUES DECLARED DISSOCIATED	
In accordance with ISO 4871	
A-weighted sound power level, LWAd (Reference 1pW), in decibels	35,0
Uncertainty KWA in decibels	3
A-weighted emission sound pressure level, LPAd (Reference 20µPa) at 1m, in decibels	27,0
Uncertainty KpA in decibels	3

Values obtained in accordance with the noise test code given in standard ISO 3744:2010, with the application of the basic standard ISO 80601-2-70.

NOTE - The sum of a measured value and the associated uncertainty represents an upper limit of the range in which the measured values are likely to be.

Static pressure stability at 10 cmH₂O

(Long-term accuracy according to ISO 80601-2-70)

	WITHOUT HUMIDIFIER	WITH HUMIDIFIER
Pressure accuracy:	± 0.5 cmH ₂ O	± 0.5 cmH ₂ O

The worst-case breathing gas pathway configuration is the configuration with a basic standard tube (15 mm) with an optional fine filter with or without humidifier.

The accuracy quoted for static pressure already includes the system uncertainties from the test equipment, i.e. ±0,75% of reading or ±0,1cmH₂O.

Dynamic pressure stability

(Short-term accuracy according to ISO 80601-2-70)

	Respiratory frequency (breaths/min)		
	10	15	20
WITHOUT HUMIDIFIER			
Maximum variation in dynamic pressure (cmH ₂ O)	± 0,5	± 0,5	± 0,7
WITH HUMIDIFIER			
Maximum variation in dynamic pressure (cmH ₂ O)	± 0,5	± 0,5	± 0,7

The worst-case breathing gas pathway configuration is the configuration with a basic standard tube (15 mm) with an optional fine filter with or without humidifier.

The accuracy quoted for dynamic pressure already includes system uncertainties from test equipment of ±(0,75% of reading + 0,04 cmH₂O).

Maximum flow and pressure

(According to ISO 80601-2-70)

	Test pressure (cmH ₂ O)				
	4	8	12	16	20
WITHOUT HUMIDIFIER					
Pressure measurement at 40 l/min at the patient orifice (cmH ₂ O)	4,12	8,15	12,18	16,25	20,28
Maximum flow rate resulting in a pressure drop of 1 cmH ₂ O at the patient's orifice (lpm)	150	182	181	169	169
WITH HUMIDIFIER					
Pressure measurement at 40 l/min at the patient orifice (cmH ₂ O)	4,12	8,08	11,85	15,96	20,00
Maximum flow rate resulting in a pressure drop of 1 cmH ₂ O at the patient's orifice (lpm)	150	166	167	162	162

The most unfavourable configuration for the passage of respiratory gases is the configuration with a 15 mm breathing tube and an optional fine filter, with or without a humidifier.

Functional diagram of the internal pneumatic circuit

Device with side cover

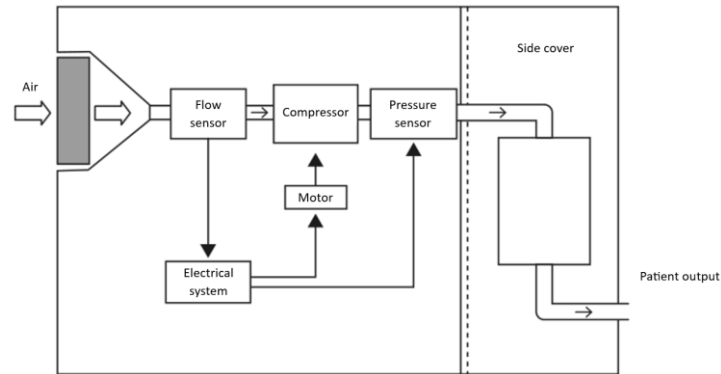

Device with humidifier

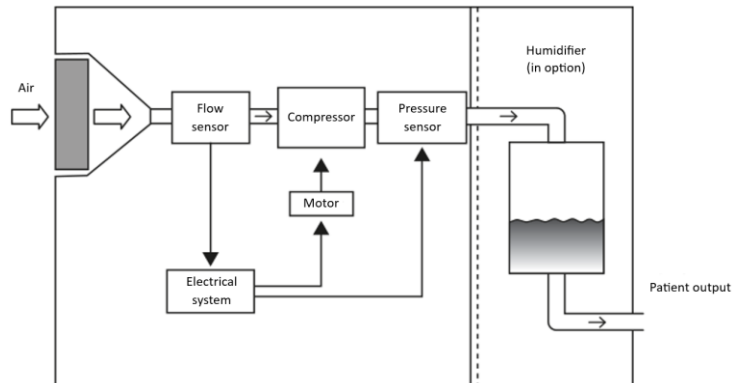

Pneumatic diagram ISO 80601-2-70

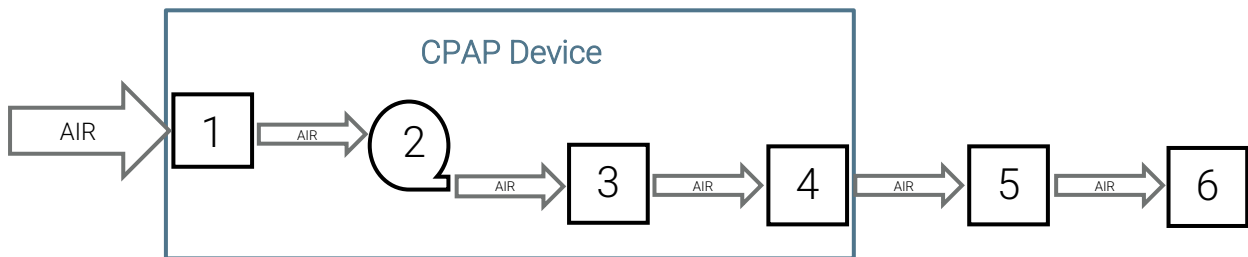

N°	Function
PPC Device	
1	Filter and air inlet
2	Blower
3	Humidifier (optional)
4	Air outlet
Applied parts (Accessories)	
5	1.80m tube
6	Mask

Special characteristics according to the standard ISO 80601-2-74

Humidifier Performance

Mask Pressure cmH ₂ O	Nominal system output mg/L	
	Setting 1 (min)	Setting 10 (max) ¹
4	>4	>10
20	>4	>10

¹Humidifier performance meets ISO 80601-2-74 : 2021 performance > 10 mg/L tested at 15°C to 35°C

EC Marking

Date of EC marking for Néa Info et Auto: 2024/04/02

End of life disposal of the device

In accordance with European Directive 2012/19/EU, this device constitutes electrical and electronic equipment whose waste must be collected and treated separately from household waste. Recycling electrical equipment preserves natural resources and avoids any risk of pollution. To this end, SEFAM fulfills its obligations regarding the end-of-life of the Néa device by financing Recylum's recycling channel dedicated to WEEE Pro, which takes them back free of charge (more information on www.recylum.com). Improper disposal of your Néa at the end of its useful life may have harmful consequences for the environment.

Use your local collection and recycling system for waste electrical and electronic equipment (e.g. drop it off at your local special waste collection center, in the container reserved for electronic waste).

If the European directive does not apply in your country, please dispose of this device in accordance with local regulations.

Contact details for your Home Healthcare Provider

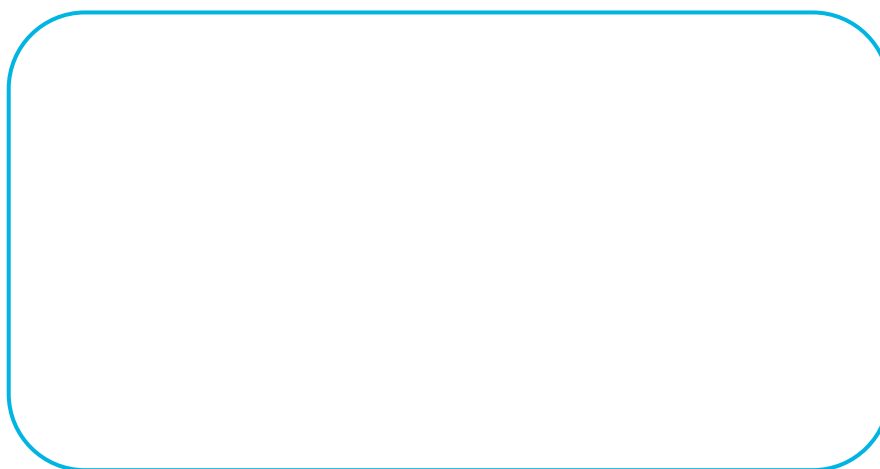

Manufacturer :

SEFAM
144 AV CHARLES DE GAULLE
92200 NEUILLY-SUR-SEINE
FRANCE

Manufacturing site :

SEFAM
10 ALLEE PELLETIER DOISY
54600 VILLERS-LES-NANCY
FRANCE